

Chargebuster Plus Single-fan Ionizer Installation, Operation, and Maintenance



Made in Japan



Figure 1. Desco Chargebuster Plus Single-fan Ionizer

Description

The Desco 60503 Chargebuster Plus Single-fan Ionizer is used for neutralizing electrostatic charges on insulators and ungrounded conductors. Its fast discharge times (< 1 second at 12 inches) and ± 10 volt offset voltage exceed the required limits of ANSI/ESD S20.20 and ESD TR53. The 60503 Chargebuster Plus Single-fan Ionizer monitors its offset voltage (balance), and it alarms when emitter cleaning is required. A built-in automatic emitter point cleaner periodically brushes away dust and minimizes maintenance. The Chargebuster Plus Single-fan Ionizer features a powder coated steel enclosure, multi-mount stand, and terminal block with alarm output for machine integration.

The Chargebuster Plus Single-fan Ionizer operates on Steady-state DC. Steady-state DC systems consist of separate negative and positive ion emitters connected by a pair of high-voltage cables to their respective high-voltage power supplies. DC power is constantly applied to the emitter points. The ionizer utilizes sampling from its inner fan grill to continuously adjust the output and maintain its offset voltage.

“The primary method of static charge control is direct connection to ground for conductors, static dissipative materials, and personnel. A complete static control program must also deal with isolated conductors that cannot be grounded, insulating materials (e.g., most common plastics), and moving personnel who cannot use wrist or heel straps or ESD control flooring and footwear. Air ionization is not a replacement for grounding methods. It is one component of a complete static control program. Ionizers are used when it is not possible to properly ground everything and as backup to other static control methods. In clean rooms, air ionization may be one of the few methods of static control available.” [ESD Handbook ESD TR20.20 Ionization, section 5.3.6.1 Introduction and Purpose / General Information]

The Chargebuster Plus Single-fan Ionizer and its accessories are available as the following item numbers:

Item	Description
60503	Chargebuster Plus Single-fan Ionizer with North America Power Adapter
60504	Replacement North America Power Adapter
60466	Ionizer Boom Arm

Packaging

- 1 Chargebuster Plus Single-fan Ionizer
- 1 Ground Wire
- 1 Power Adapter
- 1 North America Power Cord
- 1 Certificate of Calibration

Features and Components



Figure 2. Chargebuster Plus Single-fan Ionizer features and components

- A. Power Switch:** Powers the ionizer ON and OFF.
- B. Ion Balance Dial:** Use a flat-blade screwdriver to rotate the dial clockwise to change the ion balance in the positive direction and counterclockwise to change the ion balance in the negative direction.
- C. Status LED:** Provides 6 different indications. See the table below.

Indicator	Status
Green	Normal operation
Blinking orange once per 1.6 seconds	Maintenance needed or ion balance dial is not set to 0V
Blinking red once per 1.6 seconds	Fan does not rotate
Blinking red twice per 1.6 seconds	High-voltage module failure
Blinking red three times per 1.6 seconds	Ion balance out of control
Blinking red four times per 1.6 seconds	Drive failure in emitter point cleaner

- D. Fan Speed Dial:** Use a Phillips-head screwdriver to rotate the dial clockwise to increase the fan speed or counterclockwise to decrease the fan speed.
- E. Terminal Block:** Wires to external power provided by a machine and outputs an alarm signal. See "Terminal Block Setup" on page 3 for more information.
- F. Power Inlet:** Connect the included power adapter here.

Installation

Hardware Setup

Place the Chargebuster Plus Single-fan Ionizer at a desired location where the airflow will not be restricted. Ensure a space of at least 4 inches (10 cm) at the rear and on both sides of the ionizer to provide sufficient airflow. Use the tilt lock knobs to aim the ionizer at the area to be neutralized. Ensure that the power switch is set to OFF. Connect the ionizer's power cord into an appropriate AC power source.

Note that placement of the ionizer is important in determining its effectiveness. The distance from the targeted object and fan speed affect the ionizer's performance. The discharge time will increase as the distance increases or fan speed is reduced.

Terminal Block Setup

Use insulated wires in 18-24 AWG size for wiring to the terminal block.

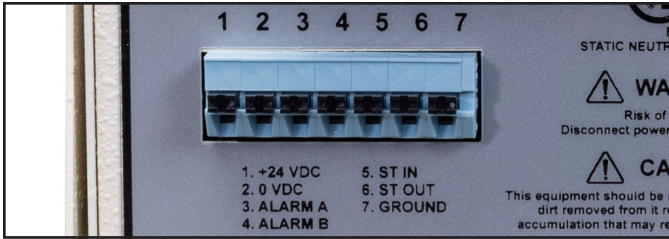

Figure 3. Terminal block

Terminals 1 and 2 are for power input from a 24 VDC supply when not using the included power adapter.

Terminals 3 and 4 are for alarm output. They are used for open collector output (up to 30 V and 100 mA). Current flows between terminals 3 and 4 (GND) on the terminal block when an alarm is output.

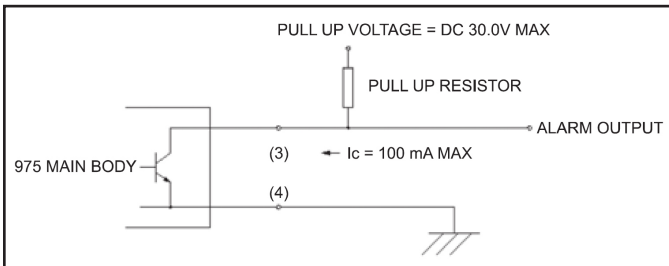

Figure 4. Alarm open collector wiring diagram

Terminals 5 and 6 control the timing of the emitter point cleaner. When multiple units are fed from the same power supply, the rated power of the supply may become insufficient if cleaning occurs simultaneously.

To avoid this situation:

- Prepare a power supply that can provide the total power needed for simultaneous cleaning. Terminals 5 and 6 are not used in this case.
- Make connections between the terminal blocks on multiple units to avoid a peak of power consumption at one time by allowing cleaning to occur in sequence. See below.

Connect the ionizers as shown below. This will make Unit I work as a master and Units II, III, and IV as slaves so that the four sets of emitter points are cleaned one after the other.

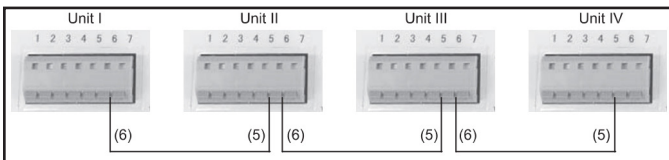

Figure 5. Wiring terminals 5 and 6 to multiple ionizers

Terminal 7 is for grounding the ionizer. Grounding is required when using the terminal block to power the ionizer instead of the included power adapter.

Operation

1. Position the ionizer so that maximum airflow is directed towards the items or area to be neutralized.
2. Rock the power switch to the ON position. The status LED will illuminate green during normal operation.
3. Set the fan speed dial to the desired setting. Higher airflow will result in faster discharge times.



Figure 6. Using the Chargebuster Plus Single-fan Ionizer on a workbench

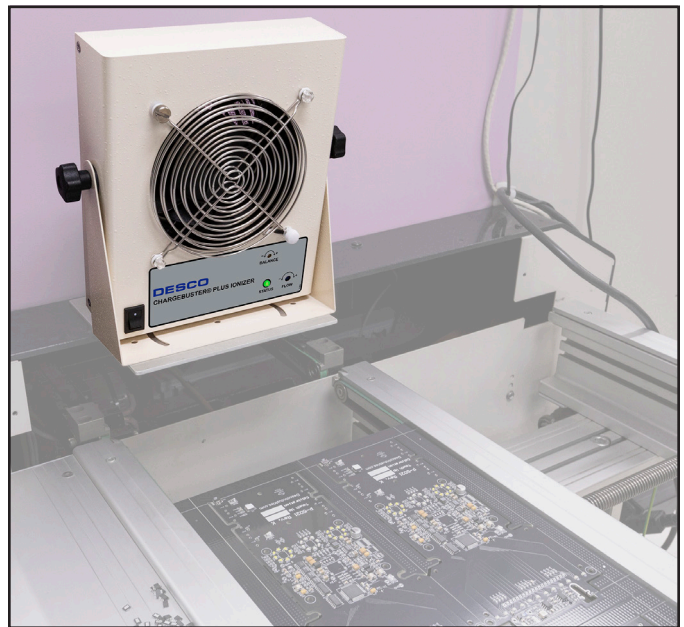

Figure 7. Using the Chargebuster Plus Single-fan Ionizer at a machine station

Maintenance

Occasional cleaning of the case and of the ionizing electrodes are the only routine maintenance procedures required.

Cleaning the Enclosure

Wipe the enclosure with a soft cloth moistened with water. If a stronger cleaning solution is required, mild soap with water may be used. The use of any other cleaning solutions is not recommended.

Cleaning the Emitter Points

CAUTION: Disconnect the power to the ionizer whenever cleaning the emitter points.

When the emitter points become dirty, the internal circuitry of the ionizer will be automatically adjusted to emit an equal amount of positive and negative ions. The automated brushes will keep the emitter points clean by brushing them 8 times per cleaning cycle. The cycle runs hourly. Particulates on the emitter point may, however, inhibit ionization to a limited degree. The emitter points are located behind the front grills. A jet of clean, compressed air can be used to remove dirt on emitter points. If a more rigorous cleaning method is needed to remove particulate, clean the points with the Desco [60506](#) Emitter Point Cleaner a cotton swab dampened with isopropyl alcohol. Access to the points is available through the front grill. Be careful not to damage the points during cleaning.

Calibration

The Desco Chargebuster Plus Single-fan Ionizer is factory adjusted to provide optimum performance. Further adjustment in the field is not possible. However, the following instructions can be followed to determine whether the ionizer is performing to specifications. The testing follows the procedure outlined in the standard for Ionization, ANSI/ESD STM3.1. Please refer to this standard for more complete information.

Frequency of recalibration should be based on the critical nature of those ESD sensitive items handled and the risk of failure for the ESD protective equipment and materials. In general, Desco recommends that calibration be performed annually.

Periodically measure the balance and neutralization times of the ionizer to verify that it is performing within specifications. These measurements should be taken using a charged plate monitor. Calibration should be performed in accordance with the ESD Association ionization standard ANSI/ESD STM3.1. With the ionizer positioned a distance of 12 inches (30 cm), the neutralization (discharge) time of $\pm 1000V$ to $\pm 100V$ should be less than 1.5 seconds, and the balance should be $\pm 10V$ or better.

Specifications

Input Voltage and Frequency (External Adapter)	Power Input: 100-240 VAC, 50/60 Hz Power Output: 24 VDC, 2.7 A Power Adapter Cable Length: 5.0' (1.5 m) Power Cord Length: 6' (1.8 m)
Operating Environment	50° to 104° F (10° to 40° C) 20 to 70% R.H.
Neutralization (Discharge) Time at 12"	< 1 second
Offset Voltage (Balance) at 12"	± 10 V typical
Ion Emission	Steady-state DC
Airflow	128 CFM max. (3.63 m ³ /min)
Ozone	<0.05 ppm
Power Consumption	20 W
Emitter Points	Tungsten
Dimensions (without stand)	7.9" H x 6.7" W x 2.8" D (200 mm x 170 mm x 72 mm)
Weight	3.2 lbs (1.5 kg)
Certifications	UL
Patents	U.S. 8,724,286; 9,948,071 Japan 5,341,330
Country of Origin	Japan

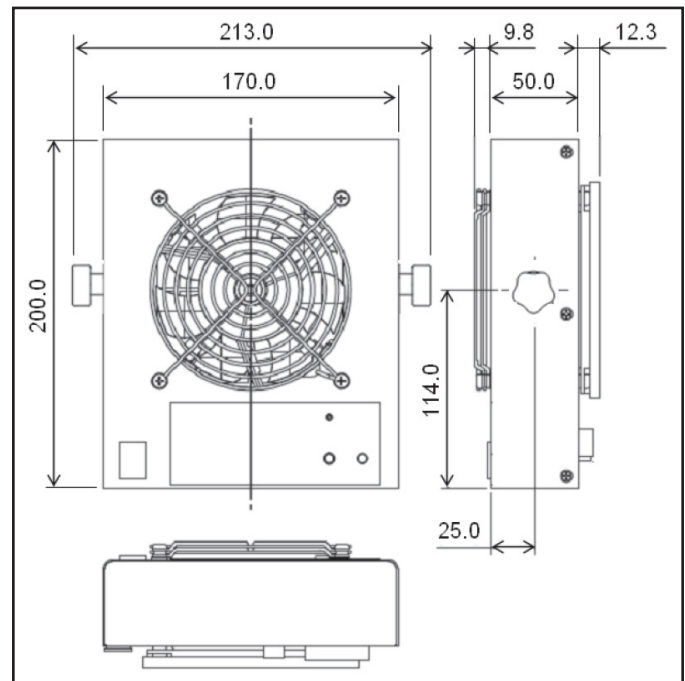

Figure 8. General dimensions in mm

Neutralization (Discharge) Times

The comparative efficiency of bench top ionizers is determined by a standard test published by the ESD Association: ANSI/ESD STM3.1. Typical positive and negative decay times ($\pm 1000V$ to $\pm 100V$) measured using this standard are shown in Figure 9.

NOTE: All discharge times are in seconds and representative only. They are not a guarantee. The discharge times were recorded in a factory ambient environment.

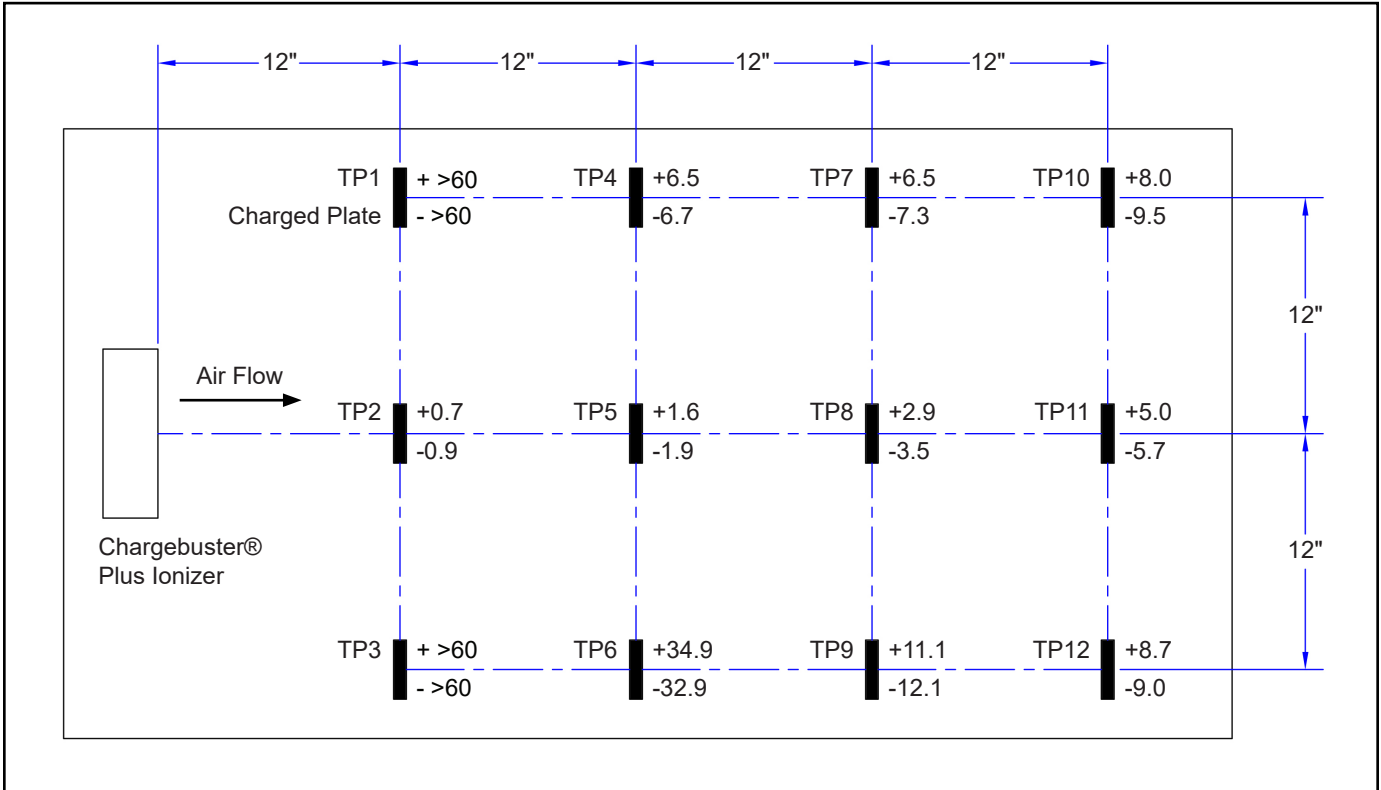

Figure 9. Neutralization (discharge) times in seconds

Safety Precautions

WARNING

- Never attempt to disassemble or modify the unit, or alter or repair circuits, as the unit contains components that generate high voltage. Do not directly touch the inside of the machine, including the electrode needles. Doing so may result in severe or fatal injury due to the hazardous high voltage generated internally, or cause a fire or malfunction of the unit.
- The unit does not incorporate explosion-proof specifications. Never attempt to use it in a place where there are flammable or volatile gases. Doing so may ignite the gases and cause an explosion.

CAUTION

- When doing electrode needle maintenance, be sure to remove the sheathed wire (routed from an external power supply) from the unit or disconnect the AC adapter plug from the outlet. Do not connect or disconnect the power plug with wet hands as doing so puts you at risk of electrical shock or injury.
- Do not insert fingers into the front louver or moving parts of the unit as there is a risk of injury.
- The unit is designed to be used with DC 24V or the dedicated AC adapter. Do not use it with incorrect voltage as that may cause a failure.
- Be sure to ground the GND terminal on the external terminal block through a ground cable. Failure to do so may result in electrical shock.
- Do not use terminal 1 to power the ionizer when using the external power adapter.
- Use the unit for the purpose of electrostatic elimination only.
- Do not use the unit in a closed room for a long period of time. If it is used in a closed room, be sure to periodically ventilate the room. The unit emits a small amount of ozone. Prolonged use in a hermetically sealed space will increase ozone density, which is harmful to the human body.
- In order to prevent accidents, if any of the following problems occur, turn OFF the switch and remove the sheathed wire (routed from an external power supply) from the unit or disconnect the AC adapter plug from the outlet. Be sure to contact Desco customer service to request inspection and repair. Repairing the product yourself is dangerous. Never attempt to do so.
 - The fan sometimes does not rotate when the switch is turned ON.
 - The fan rotates in an abnormally slow or irregular manner.
 - The fan rotates but makes abnormal noises.
 - The unit becomes abnormally hot or you smell a burning odor.
 - Any other abnormality or malfunction occurs.

Limited Warranty, Warranty Exclusions, Limit of Liability and RMA Request Instructions

See the Desco Warranty - Desco.com/Limited-Warranty.aspx