



Techcon
TS5624DMP
Disposable Material Path
Diaphragm Valve

User Guide



CONTENTS

| | Page number |
|--|-------------|
| 1. Specifications..... | 3 |
| 2. Unpacking and Inspection..... | 4 |
| 3. Description..... | 4 |
| 4. Theory of Operation..... | 4 |
| 5. Setup Instructions..... | 5 |
| 6. Typical System Set-Up..... | 6 |
| 7. Disposable Material Path Removal/Replacement..... | 7 |
| 8. Maintenance of Air Cylinder O-Ring..... | 8 |
| 9. Spare Parts..... | 9 |
| 10. Accessories..... | 10 |
| 11. Troubleshooting..... | 11 |
| 12. Warranty..... | 12 |

1. SPECIFICATIONS

| | TS5624DMP |
|--------------------------|--|
| Size | See below illustration |
| Weight | 0.25 lb. (113g) |
| Fluid Inlet Port | Luer lock female |
| Fluid Outlet Port | Luer lock male |
| Air Inlet Port | 10-32 UNF |
| Auxiliary Air Inlet Port | 10-32 UNF |
| Minimum Air Pressure | 70 psi (4.8bar) |
| Maximum Fluid Pressure | 60 psi (4.1bar) |
| Operating Frequency | Exceeds 400 cycles/min. |
| Mounting Port | 10-32 UNF |
| Wetted Parts | Black Polyethylene Compound. Black Nylon (Elbow). |

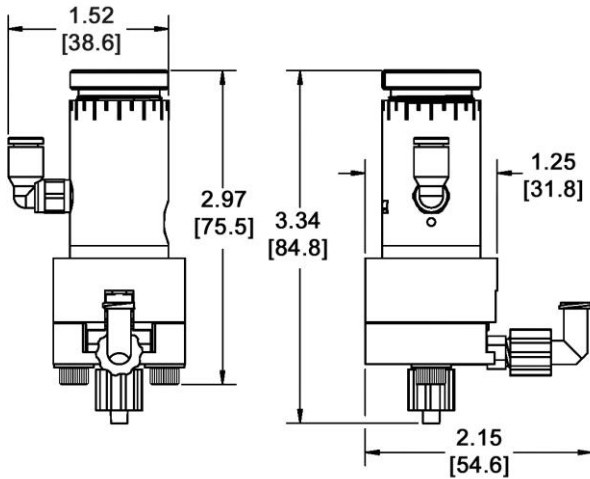

Dimensions are in inches [mm]

Figure 1.0

2. UNPACKING AND INSPECTION

Carefully unpack the valve and examine the items contained in the carton. These will include:

- Valve assembly.
- Mounting bracket and mounting screw.
- 1 x Disposable Material Path.
- 2 x Hex keys (1/8" & 9/64").
- Sample tip kit.
- Fluid line and air hose.
- User guide.

3. DESCRIPTION

The TS5624DMP Diaphragm Valve is designed to dispense low to medium viscosity fluids. An internal spring return makes the valve fully adaptable for use with any time/pressure controller. A short opening stroke provides extremely fast, positive shut-off. An external stroke control adjustment makes it easy to fine tune shot sizes. The TS5624DMP Diaphragm Valves compact design allows for mounting flexibility and easy integration into automated applications.

4. THEORY OF OPERATION (Refer to figure 2.0)

The TS5624 Diaphragm Valve is normally closed, adjustable stroke valve. Input air pressure of **70-90 psi (4.8 to 6.2bar)** through air inlet port (1) drives the piston assembly (2) back, opening the material path, allowing fluid flow from the material inlet (3) to the material outlet (4). Relieving the input air pressure allows the piston return spring (5) to close the diaphragm (6), ensuring rapid "fail-safe" shut-off of fluid flow.

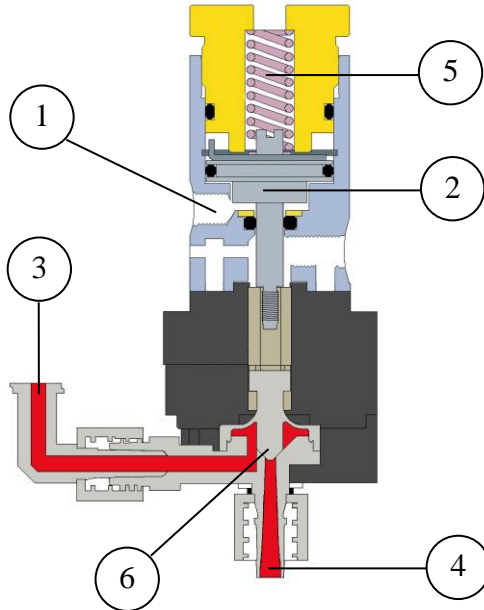

Figure 2.0

5. SETUP INSTRUCTIONS

Refer to Figure 3.0

Note: This installation uses Luer lock adapters shipped with the valve.

1. Connect the fluid feed tube or syringe to the fluid inlet port (1).
2. Connect the valve airline to the valve controller or other pneumatic device that is used to control the valve.
3. Connect the opposite end of the airline to valve air inlet (2).
4. Connect appropriate dispensing tip or nozzle to the fluid outlet port (3).
5. Set the valve controller pressure at **70 psi (4.8bar)**.
6. Set the fluid pressure. **Do not exceed 60 psi (4.1bar)**.
7. Make sure all connections are tight.
8. Place container under the outlet and activate the valve until the fluid flows steady.

The amount of fluid that flows through the valve is determined by:

- Valve open time
- Fluid reservoir pressure
- Dispensing tip size
- Stroke adjustment knob position

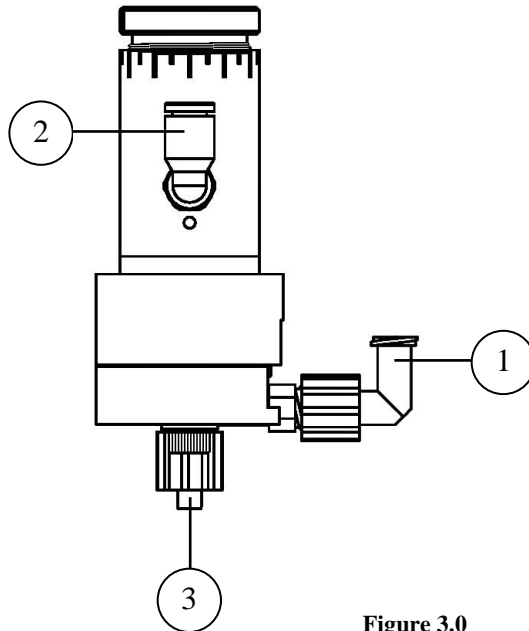

Figure 3.0

6. TYPICAL SYSTEM SET-UP

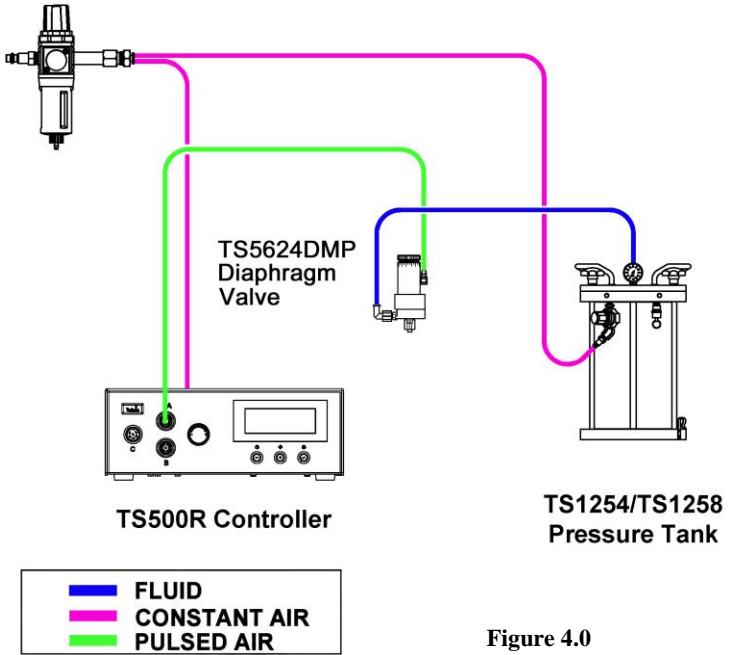

Figure 4.0

Optional Syringe Feeding

1. Attach 7509-9100 syringe bracket as shown below.
2. Use insert rings for syringe sizes 3cc – 10cc.
3. Ensure syringe is under constant air pressure.

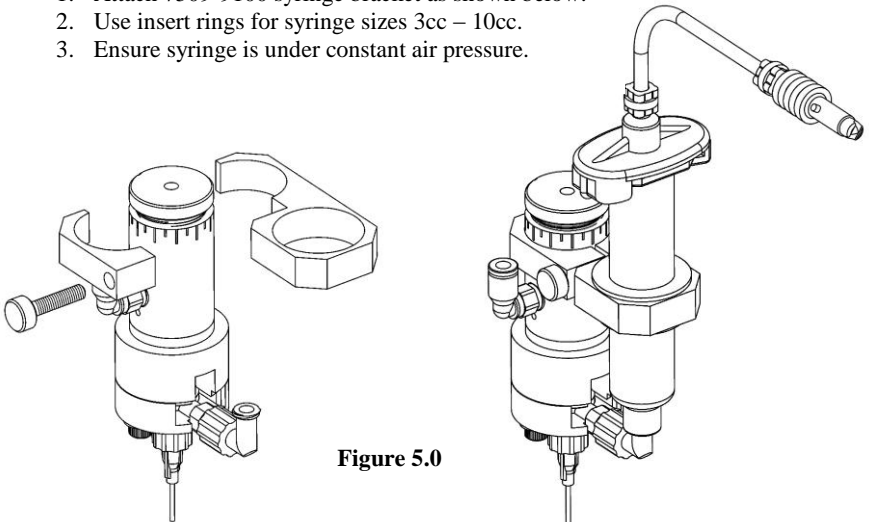

Figure 5.0

7. DISPOSABLE MATERIAL PATH REMOVAL/REPLACEMENT:

Removal of a feed path assembly: Refer to figure 6.0

1. Release fluid pressure.
2. Remove syringe barrel or fluid line from the valve.
3. Loosen the lower receiver screws (4 - 5 turns) and pull out disposable material path.
4. Dispose of the used feed path assembly in an appropriate waste container.

Installation of a new feed path assembly: Refer to figure 6.0

1. Insert a new feed path assembly into the valve housing. Ensure correct fitment into the actuator.
2. Tighten lower receiver screws to torque setting specified below.

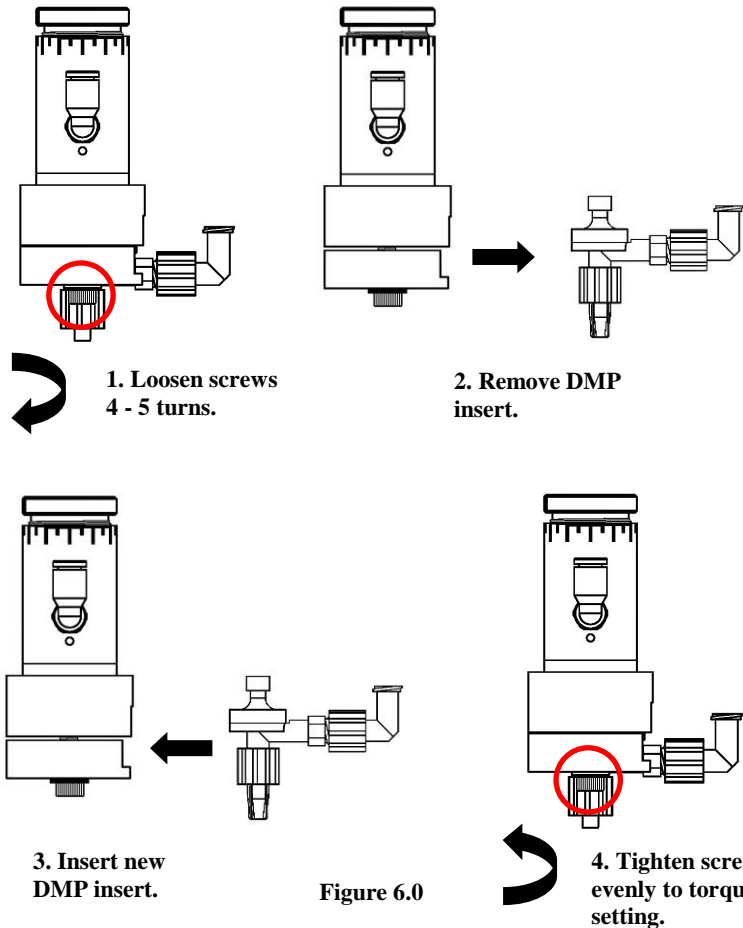

| | |
|-----------------------|----------------------|
| Torque Specifications | 14 in lb. (1.58 N-m) |
|-----------------------|----------------------|

8. MAINTENANCE OF AIR CYLINDER O-RING (Refer to figure 7.0 and 8.0)

1. Unscrew receiver screws (1).
2. Remove the DMP (2).
3. Remove the stroke control knob (3) and spring (4).
4. Remove the receiver assembly (5).
5. Remove actuator (6).
6. Remove retaining ring (7), anti-rotate washer (8) and Mylar washer (9).
7. Remove piston (10) from air cylinder (11).
8. Replace O-ring (12) if damaged; otherwise lubricate O-ring with Bimba HT-99, or equivalent.
9. Reinstall piston (10), retaining ring (7), anti-rotate washer (8) and Mylar washer (9).
10. Reinstall actuator (6) as per position in Step 4. 90° offset to the air inlet.
11. Reinstall receiver assembly (5), leaving receiver screws loose.
12. Reinstall spring (4) and stroke control knob (3).
13. Install DMP (2) and set torque on receiver screws. - 14 in lb. (1.58 N-m)

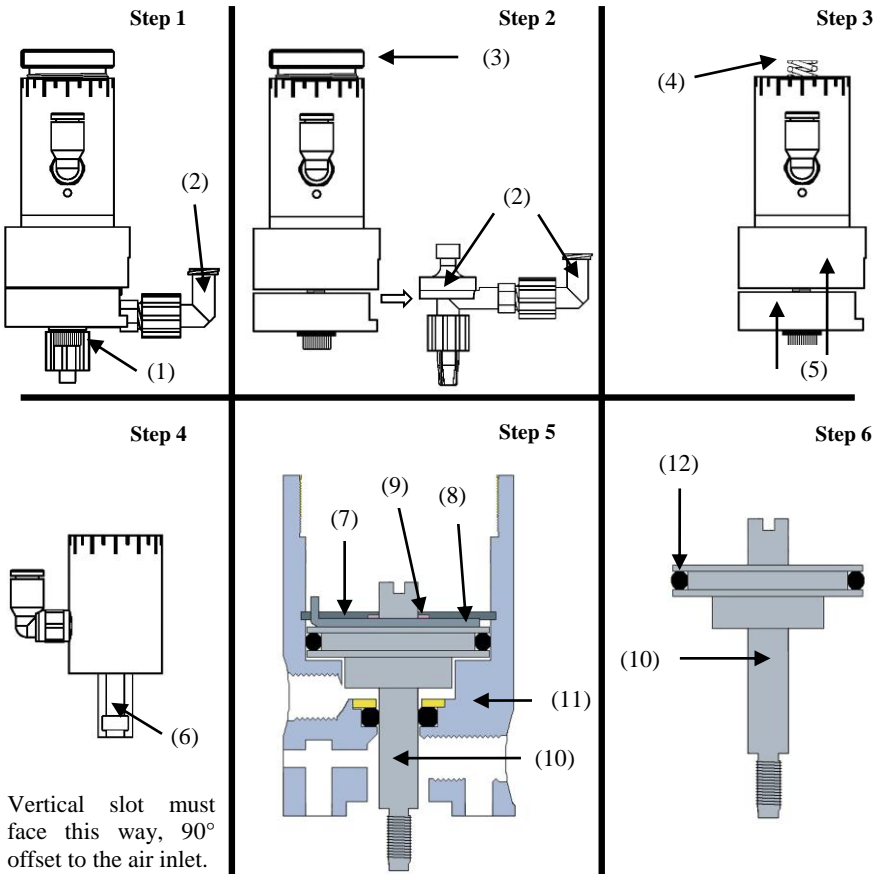

Figure 7.0

9. SPARE PARTS

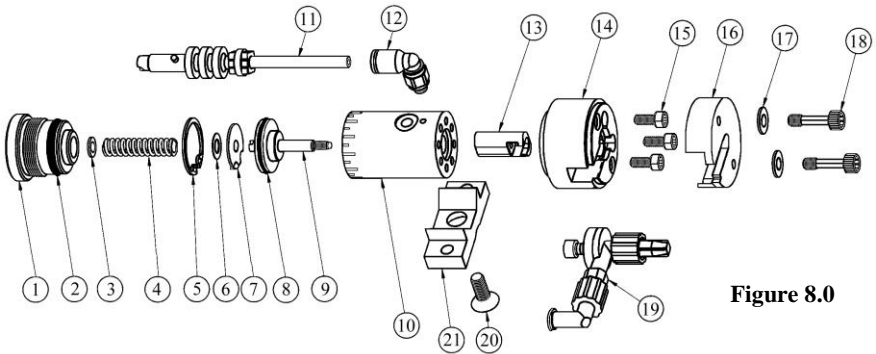

Figure 8.0

| ITEM | PART NUMBER | DESCRIPTION |
|------|----------------|---------------------------------------|
| 1 | 5620-000-004 | End Cap |
| 2 | TSD1400-111APK | End Cap O-Ring (Pack of 10) |
| 3 | 2800-0892 | Washer, SS |
| 4 | 3300-0578 | Spring |
| 5 | TSD1120-11 | Retaining Ring |
| 6 | TSD1109-43 | Mylar Washer |
| 7 | 5620-000-006 | Anti-Rotate Washer |
| 8 | TSD1400-016APK | Piston O-Ring (Pack of 10) |
| 9 | 5620-000-005 | Piston |
| 10 | 5620-000-003 | Air Cylinder |
| 11 | A0100478 | Air Hose/Connector Assembly, 4mm |
| 12 | TSD1003-20 | Air Fitting, 4mm, Elbow |
| 13 | 7509-0250 | Actuator |
| 14 | 7509-0270 | Upper Receiver |
| 15 | 2800-0463 | Upper Receiver Screw |
| 16 | 7509-0280 | Lower Receiver |
| 17 | 2800-0236 | Washer |
| 18 | 2800-0886 | Screw |
| 19 | DMP-5624 | Disposable Material Path (Pack of 10) |
| 20 | TSD1106-13 | Mounting Screw |
| 21 | 918-000-048 | Mounting Bracket |
| 22 | 7509-9100 | Syringe Bracket W/Inserts (See Fig.5) |

Lubrication: All O-Rings must be lubricated with Bimba HT-99, or equivalent.

Receiver Mounting Screws Torque (Item 18): 14 in lb. (1.58 N-m).

10. ACCESSORIES

| PART NUMBER | DESCRIPTION |
|--------------|-----------------------------|
| TS918-46 | 4-Way Fluid Manifold |
| TN00DKIT | Complete Dispensing Tip Kit |
| 9000-000-100 | Sample Tip Kit |

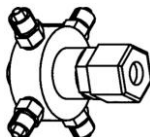

10.1 FLUID FITTINGS AND TUBING

| PART NUMBER | DESCRIPTION |
|---------------|---|
| TSD1003-16 | 1/8" NPT to 1/4" O.D. Tube, 90° Elbow |
| TSD1002-17 | 1/8" NPT to 3/8" O.D. Tube |
| TSD1002-18 | 1/8" NPT to 1/4" O.D. Tube |
| TSD1002-38 | 1/4" NPT to 1/4" O.D. Tube |
| TSD1099-22 | 3/8" O.D. X 1/4" I.D. Tube, Black, Polyethylene |
| TSD1099-23 | 3/8" O.D. X 1/4" I.D. Tube, Clear, Polyethylene |
| TSD1099-24 | 1/4" O.D. X 1/8" I.D. Tube, Clear, Polyethylene |
| TSD1099-25 | 1/4" O.D. X 1/8" I.D. Tube, Black, Polyethylene |
| TSD1099-45 | 6mm O.D. X 4mm I.D, Clear, Polyethylene |
| TSD1099-46 | 6mm O.D. X 4mm I.D, Black, Polyethylene |
| TSD126-360BPK | Luer Lock Tubing, 60" (1524mm) , Black |

10.2 BRACKETS

| PART NUMBER | DESCRIPTION |
|--------------|---|
| 918-033-000 | Productions Master Stand (Base & Support) |
| 918-000-012 | Rod Clamp Assembly |
| 5620-000-008 | 4" (101.6mm) Threaded Mounting Rod |
| 7509-9100 | Syringe Bracket With Inserts |

11. TROUBLE SHOOTING

| PROBLEM | POSSIBLE CAUSE | CORRECTION |
|--|--|--|
| No fluid flow | Fluid pressure too low | Increase fluid pressure |
| | Operating pressure too low | Increase air pressure to 70 psi (4.8bar) |
| | Dispense tip clogged | Replace tip |
| | Fluid cured in valve chamber | Replace material path |
| | Stroke adjustment closed | Open stroke adjustment counterclockwise |
| Inconsistent fluid flow | Fluid pressure fluctuating | Ensure fluid pressure is constant |
| | Valve operating pressure is too low | Increase valve pressure to 70 psi (4.8bar) |
| | Valve open time is not consistent | Check to make sure the valve controller is providing a consistent output |
| | Air trapped in fluid housing | Purge valve |
| Fluid drools after the valve closes, eventually stopping | Air trapped in fluid chamber | Purge valve |
| Steady drip | Worn material path | Replace material path |
| | Fluid pressure exceeds 60 psi (4.1bar) | Lower fluid pressure |

12. LIMITED WARRANTY

Manufacturer warrants this product to the original purchaser for a period of one (1) year from date of purchase to be free from defects in material and workmanship, but not against damages by misuse, negligence, accident, faulty installations and instructions. Manufacturer will repair or replace (at factory's option), free of charge, any component of the equipment thus found to be defective, on return of the component, "PREPAID" to the factory during the warranty period. In no event shall any liability or obligation of the Manufacturer arising from this warranty exceed the purchase price of the equipment. This warranty is only valid if the defective product is returned as a complete assembly without physical damage. The Manufacturer's liability, as stated herein, cannot be altered or enlarged except by a written statement signed by an officer of the company. In no event shall the Manufacturer be liable for consequential or incidental damages. A return authorization is required from Techcon Systems prior to shipping a defective unit to the factory.

Manufacturer reserves the right to make engineering product modifications without notice.

All returns must be issued with a Returns Authorization number, prior to return. Send warranty returns to:

Americas and Asia

OK International
10800 Valley View Street
Cypress, CA 90630 USA

Europe

OK International
Eagle Close
Chandler's Ford Ind Est
Eastleigh
Hampshire
SO53 4NF
United Kingdom



7000-4760_A