

Techcon Systems
TS5420
TS5420SS
Needle Valve

User Guide



CONTENTS

	Page number
1. Specifications.....	3
2. Unpacking and Inspection.....	4
3. Description.....	4
4. Theory of Operation.....	4
5. Setup Instructions.....	5
6. Typical System Set-Up.....	6
7. Maintenance and Cleaning.....	7-8
8. Spare Parts.....	9-10
9. Repair Kits.....	11
10. Accessories.....	12
11. Troubleshooting.....	13
12. Warranty.....	14

12. LIMITED WARRANTY

Manufacturer warrants this product to the original purchaser for a period of one (1) year from date of purchase to be free from defects in material and workmanship, but not against damages by misuse, negligence, accident, faulty installations and instructions. Manufacturer will repair or replace (at factory's option), free of charge, any component of the equipment thus found to be defective, on return of the component, "PREPAID" to the factory during the warranty period. In no event shall any liability or obligation of the Manufacturer arising from this warranty exceed the purchase price of the equipment. This warranty is only valid if the defective product is returned as a complete assembly without physical damage. The Manufacturer's liability, as stated herein, cannot be altered or enlarged except by a written statement signed by an officer of the company. In no event shall the Manufacturer be liable for consequential or incidental damages. A return authorization is required from Techcon Systems prior to shipping a defective unit to the factory.

Manufacturer reserves the right to make engineering product modifications without notice.

All returns must be issued with a Returns Authorization number, prior to return. Send warranty returns to:

Americas and Asia

OK International
Garden Grove Division
12151 Monarch Street
Garden Grove, Ca 92841

Europe

OK International
Eagle Close
Chandler's Ford Ind Est
Eastleigh
Hampshire
SO53 4NF
United Kingdom

Delrin® and Teflon® is a registered trademark of E.I. DuPont.

1. SPECIFICATIONS

	TS5420	TS5420SS
Size	4.6" Length X 1.1" (117mm X 28.5mm)	4.6" Length X 1.1" (117mm X 28.5mm)
Weight	0.3 lb (136g)	0.5 lb (227g)
Fluid Inlet Port	1/8" NPT female	1/8" NPT female
Fluid Outlet Port	Luer Lock	Luer Lock
Air Inlet Port	10-32 UNF	10-32 UNF
Auxiliary Air Inlet Port	10-32 UNF	10-32 UNF
Minimum Air Pressure	70 psi (4.8bar)	70 psi (4.8bar)
Maximum Fluid Pressure	300 psi (20.7bar)	300 psi (20.7bar)
Operating Frequency	Exceeds 400 cycles/min.	Exceeds 400 cycles/min.
Mounting Port	1/4-20 UNC-2B	1/4-20 UNC-2B
Wetted Parts	Type 303 SS, Al., Teflon®, EPR	Type 303 SS, Teflon®, Delrin®, EPR

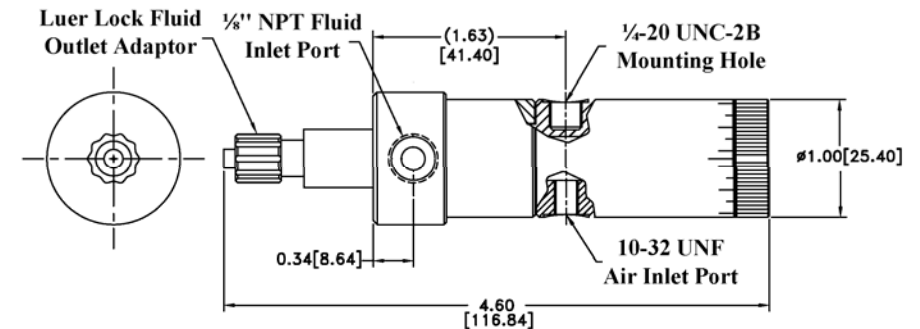

Dimensions are in inches [mm]

Figure 1.0

TSI-0222_F

2. UNPACKING AND INSPECTION

Carefully unpack the valve and examine the items contained in the carton.

These will include:

- Valve Assembly
- Valve bracket and air hose
- Sample tip kit and fluid line
- User guide

3. DESCRIPTION

The TS5420 Needle Valve is designed to dispense low to medium viscosity material with very precise deposits over a wide range of shot and bead sizes, down to a fraction of a micro liter. An internal spring return makes the valve fully adaptable for use with Techcon Systems time/pressure controllers. A short opening stroke provides extremely fast, positive shut-off. An external stroke control adjustment makes it easy for the operator to fine tune shot sizes. The TS5420's compact design allows for mounting flexibility and easy integration into automated applications.

4. THEORY OF OPERATION

The TS5420 Needle Valve is a normally closed, adjustable opening, needle and seat valve. Inlet air pressure through port (1) retracts the needle assembly (2) from the seat (3) allowing fluid to flow from the valve fluid inlet (4) to the Luer lock outlet (5). Relieving the input air pressure allows the spring (6) to return the needle back to its position to close the material path.

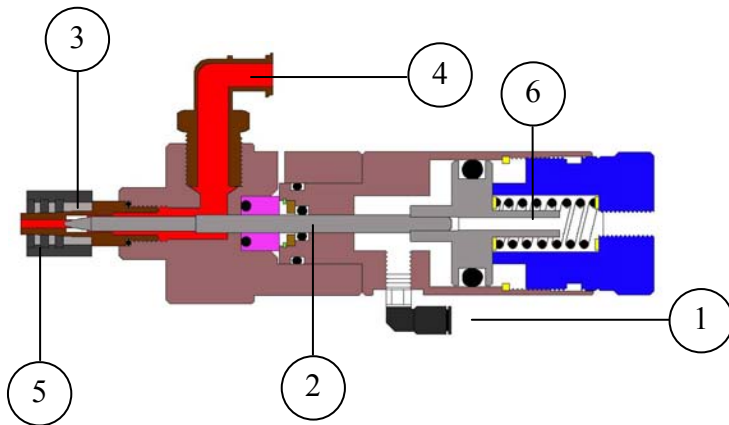

Figure 2.0

11. TROUBLE SHOOTING

PROBLEM	POSSIBLE CAUSE	CORRECTION
No fluid flow	Fluid pressure too low	Increase fluid pressure
	Operating pressure too low	Increase air pressure to 70 psi (4.8bar)
	Dispense tip clogged or damaged	Replace tip
	Fluid cured in valve chamber	Clean valve thoroughly
	The stroke adjustment closed	Open stroke adjustment counterclockwise
Inconsistent fluid flow	Fluid pressure fluctuating	Make sure fluid pressure is constant
	Valve operating pressure is too low	Increase valve pressure to 70 psi (4.8bar)
	Valve open time is not consistent	Check to make sure the valve controller is providing a consistent output
	Air trapped in fluid housing	Purge valve
Fluid drools after the valve closes, eventually stopping	Air trapped in fluid housing	Purge valve
Steady drip	Dirty needle and seat	Perform thorough cleaning
	Worn needle and seat	Replace worn or damaged part
	Fluid pressure exceeds 300 psi (20.7bar)	Lower fluid pressure
	Valve re-assembled incorrectly	Re-assemble valve follow instructions

10. STANDARD ACCESSORIES

PART NUMBER	DESCRIPTION
7305XCON	Cleaning Gel, 30cc Syringe

10.1 OPTIONAL ACCESSORIES

PART NUMBER	DESCRIPTION
TS918-46	4-Way Fluid Manifold
TN00DKIT	Complete Dispensing Tip Kit
9000-000-100	Sample Tip Kit
5420-SIT	Seal Insertion Tool

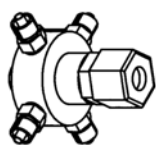

10.2 FLUID FITTINGS AND TUBING

PART NUMBER	DESCRIPTION
TSD1003-16	1/8" NPT to 1/4" O.D. Tube, 90° Elbow
TSD1002-17	1/8" NPT to 3/8" O.D. Tube
TSD1002-18	1/8" NPT to 1/4" O.D. Tube
TSD1002-38	1/4" NPT to 1/4" O.D. Tube
TSD1099-22	3/8" O.D. X 1/4" I.D. Tube, Black, Polyethylene
TSD1099-23	3/8" O.D. X 1/4" I.D. Tube, Clear, Polyethylene
TSD1099-24	1/4" O.D. X 1/8" I.D. Tube, Clear, Polyethylene
TSD1099-25	1/4" O.D. X 1/8" I.D. Tube, Black, Polyethylene
TSD1099-45	6mm O.D. X 4mm I.D, Clear, Polyethylene
TSD1099-46	6mm O.D. X 4mm I.D, Black, Polyethylene
TSD126-360BPK	Luer Lock Tubing, 60" (1524mm) , Black

10.3 BRACKETS

PART NUMBER	DESCRIPTION
918-033-000	Productions Master Stand (Base & Support)
918-000-012	Rod Clamp Assembly
1212-000-008	6" (152.4mm) Threaded Mounting Rod

5. SETUP INSTRUCTIONS

Refer to Figure 3.0

Note: This installation uses Luer lock adapters shipped with the valve. Any approved material line with 1/8" NPT connections will work.

- 1) If desired, mount the valve to the bracket included.
- 2) Connect fluid feed line to valve inlet port (1).
- 3) Install valve actuating air hose to air inlet port (2).
- 4) Connect valve air hose to an approved valve controller, such as the TS500R.
- 5) Set the fluid reservoir pressure. Do not exceed 300 psi (20.7bar).
- 6) Make sure all connections are tight.
- 7) Place a container under the valve outlet and activate the valve until the fluid flows steady.
- 8) Attach appropriate dispense tip to the Luer lock outlet fitting (3).

The amount of fluid that flows through the valve is determined by:

- Flow control adjustment: Turn end cap counterclockwise to increase material flow rate.
- Length of actuation, set at controller (valve open time).
- Fluid reservoir pressure
- Dispense tip size

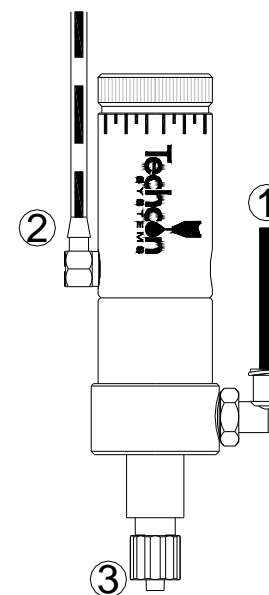

Figure 3.0

6. TYPICAL SYSTEM SET-UP

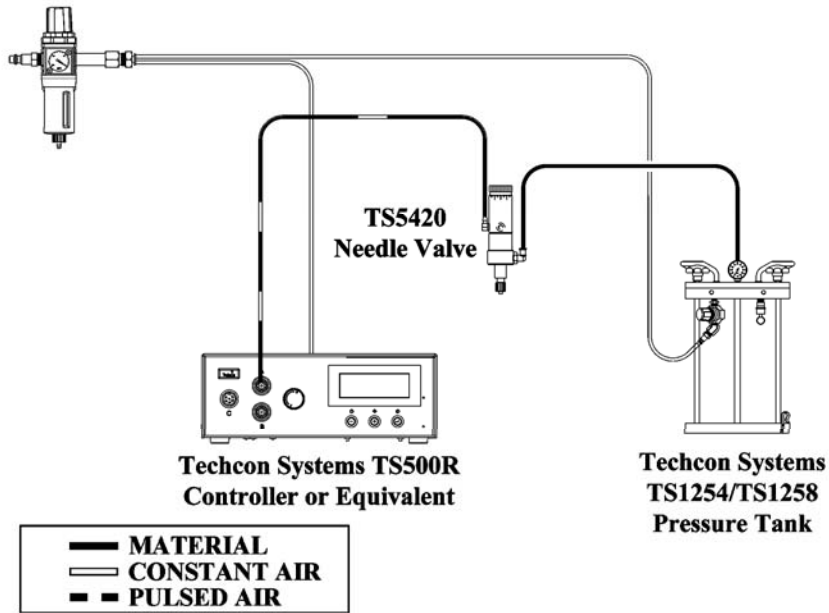
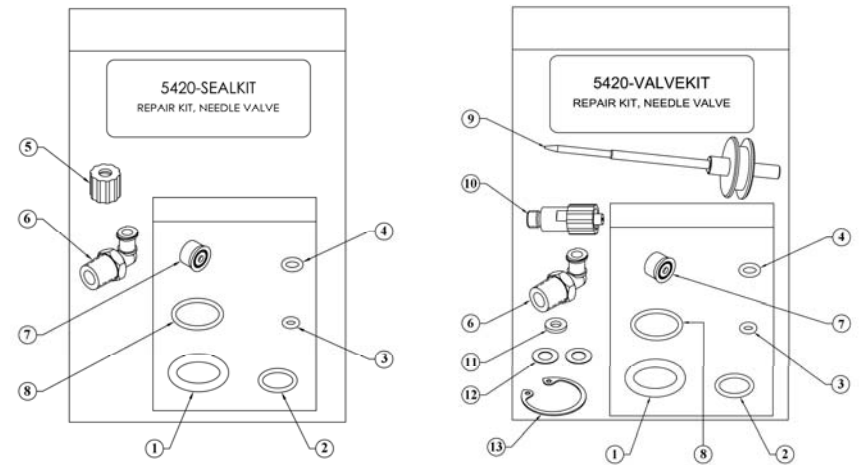

Figure 4.0

9. REPAIR KITS



*These kits are for both variations of Techcon Systems Needle Valve

ITEM	PART NUMBER	DESCRIPTION	QTY
1	TSD1400-208A	Piston O-Ring, Buna	1
2	TSD1400-013A	O-Ring, Buna	1
3	TSD1400-006A	O-Ring, Buna	1
4	TSD1400-008A	O-Ring, Buna	1
5	TSD931-44	Luer Collar	1
6	TSD931-75	Luer Lock Adaptor, Elbow	1
7	TSD400-70	U-Cup Seal	1
8	TSD1400-016A	O-Ring, Buna	1
9	5520-000-010	Needle/Piston Assembly	1
10	5420-000-007	Luer Lock Outlet Adaptor, With Seat	1
11	TSD1109-45	Nylon Washer	1
12	TSD1109-43	Mylar Washer	2
13	TSD1120-15	Retaining Ring, Large	1

SPARE PARTS, CONT.

Valve Front Section

Recommended lubricant:

All O-Rings & seals must be lubricated with Bimba HT-99, or equivalent, with the exception of TSD400-70, which must remain dry.

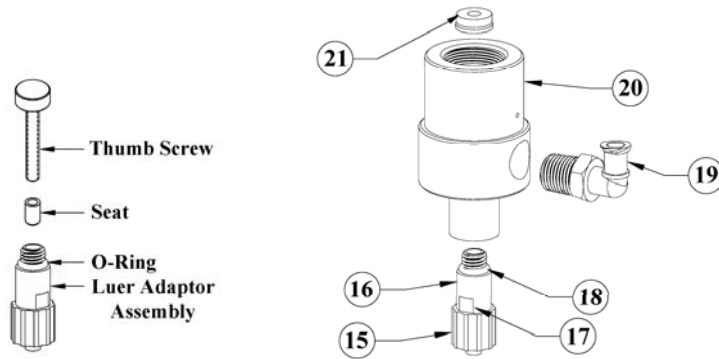

Figure 6.0

ITEM	PART NUMBER	DESCRIPTION	QTY
15	TSD931-44	Luer Lock Collar	1
16	5420-000-007	Luer Adaptor, Inc. Collar/Seat	1
17	T1000598	Nozzle Seat	1
18	TSD1400-008A	Luer Adaptor O-Ring, Buna	1
19	TSD931-75	Luer Lock Adaptor, Elbow	1
20	5420-000-002	Body, For TS5420	1
20*	5420-000-008	Body, For TS5420SS	1
21	TSD400-70	U-Cup Seal	1
Above	TSD1113-28	Thumb Screw	1

7. MAINTENANCE AND CLEANING:

Tool required: 5/8" open-end wrench; Snap ring pliers, o-ring removal tool (P/N TSD1597-7).

Normally, purging the valve with appropriate flush material or solvent after use is sufficient for cleaning. However some material may cause a buildup in the valve chamber, in this case periodic and thorough cleaning will be required.

NOTE:

- *Make sure the fluid pressure is released before valve is disassembled*
- *To replace seals, please order seal kit part number: 5420-SEALKIT*
- *To repair valve, please order valve kit part number: 5420-VALVEKIT*

7.1 Thorough Cleaning

Refer to figure 5.0

1. Release fluid pressure.
2. Disconnect fluid line and remove fluid inlet fitting.
3. Disconnect valve air hose.
4. Turn the stroke control knob (15) two turns counterclockwise from closed position.
5. Hold the fluid housing (8) and rotate the air cylinder (2) counterclockwise. When completely un-threaded, pull the two valve segments straight apart to separate.
6. Inspect o-ring (6), replace o-ring if damaged found.
7. Remove cup seal (7), replace seal if damaged found.
8. Remove Luer adapter assembly (9).
9. Clean the fluid housing (8), needle/piston assembly (5) and Luer adapter assembly (9).

NOTE: Avoid using sharp probes for cleaning. Any nicks or scratches on the seal or the surfaces of the needle/piston assembly may cause leakage.

10. Insert cup seal (7) into fluid housing (8) using 5420-SIT insertion tool. Make sure the o-ring side is facing down.
11. Reinstall Luer adapter assembly (9) to fluid housing (8).
12. Lubricate o-ring (6) with Bimba HT-99, or equivalent
13. Thread the air cylinder/needle assembly into fluid housing.
14. Make sure not to cross thread.

7.2 Nozzle Seat Replacement (refer to figure 6.0)

1. Insert the thumb screw inside the nozzle (16) and rotate clockwise to attach to the seat (17).
2. Secure the nozzle in a "soft jaw" vise and then pull the thumb screw, with the seat attached, straight out.
3. Install the new seat on the thumb screw and then insert the thumb screw straight into the nozzle. To ensure proper seat alignment, it is recommended that the seat installation is done on an Arbor Press.

7.3 To Replace Seal in Air Cylinder

1. Hold the fluid housing (8) and rotate the air cylinder (2) counterclockwise. When completely un-threaded, pull the two valve segments straight apart to separate.
2. Remove stroke control knob (15) by rotating it in counterclockwise direction.
3. Remove compression spring (1).
4. Using the snap ring pliers, remove the retaining ring (3).
5. Remove Mylar washers (14).
6. Pull the needle/piston assembly (5) straight out from the air cylinder (2).
7. Using the snap ring pliers, remove the retaining ring (11).
8. Remove the nylon washer (12) from the air cylinder.
9. Using o-ring removal tool, remove o-ring (13).
10. Replace all o-rings if necessary.
11. Lubricate all o-rings with Bimba HT-99, or equivalent.
12. Reinstall o-ring (13).
13. Reinstall nylon washer (12) and secure with retaining ring (11).
14. Thread the air cylinder (2) into fluid housing (8). Make sure not to cross thread.
15. Reinstall needle/piston assembly (5) and secure with retaining ring (3).
16. Reinstall first Mylar washer (14) on the needle/piston assembly (5).
17. Reinstall compression spring (1) into air cylinder (2).
18. Reinstall second Mylar washer (14) in the stroke control knob (15).
19. Reinstall stroke control knob (15).

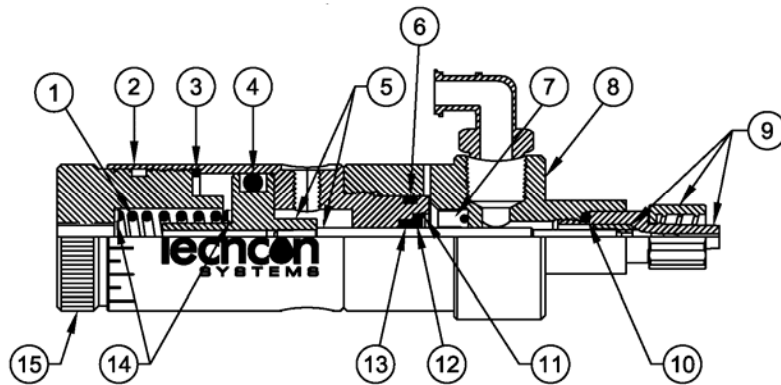

Figure 5.0

8. SPARE PARTS

Valve Rear Section

Recommended lubricant:

All o-rings & seals must be lubricated with Bimba HT-99, or equivalent.

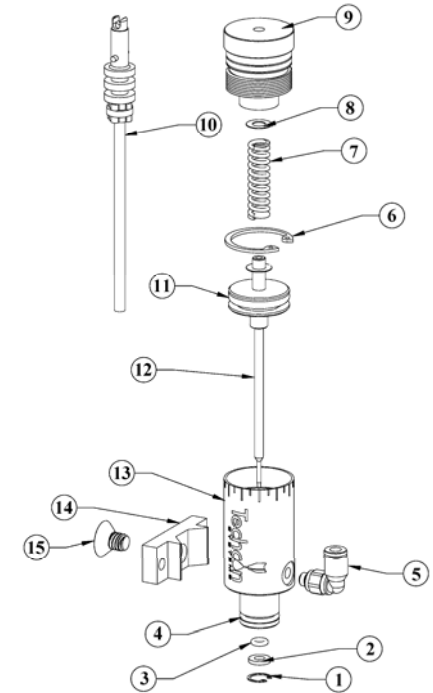

ITEM	PART NUMBER	DESCRIPTION	QTY
1	TSD1120-2	Retaining Ring, Small	1
2	TSD1109-45	Nylon Washer	1
3	TD1400-006A	O-Ring, Buna	1
4	TSD1400-013A	O-Ring, Buna	1
5	TSD1003-20	Air Fitting, 4mm, Elbow	1
6	TSD1120-15	Retaining Ring, Large	1
7	TSD1150-34	Spring	1
8	TSD1109-43	Mylar Washer	2
9	5520-000-007	End Cap, For TS5420	1
9*	T1000599	End Cap, For TS5420SS	1
10	A0100478	Air Hose/Connector Assembly, 4mm	1
11	TSD1400-208A	Piston O-Ring, Buna	1
12	5520-000-010	Needle/Piston Assembly	1
13	5520-000-001	Air Cylinder, For TS5420	1
13*	T1000600	Air Cylinder, For TS5420SS	1
14	918-000-048	Mounting Bracket	1
15	TSD1106-36	Mounting Screw	1