

BSP8 PISTOL BRUSHLESS SCREWDRIVERS

Torque Range:

0.5–4.5 Nm (4.4–40 in-lbs)

Features:

- Consistent torque output — Torque accuracy $\pm 3\%$ *
- Clean, brushless motor technology
- Dependable, long lifespan
- Two speed selections available
- Trigger start, forward/reverse switch
- LEDs and audible indicators alert user to proper clutch activation at shut-off, low battery, and current speed setting
- To conserve battery power, screwdriver enters sleep mode when idle for more than 3 seconds
- Charging station (purchased separately) provides quick recharge time (~45 minutes)
- Includes torque lock sleeve, belt clip, and 2 PH #2 driver bits



*Factory test values - actual torque results may vary depending on the specific application, operator input, and test equipment used.

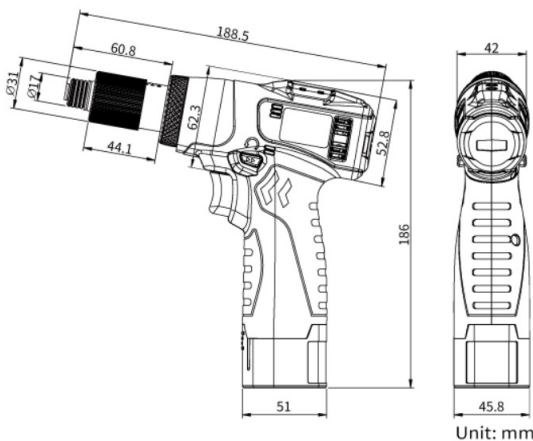

Specifications					
Model			BSP824	BSP828	BSP829
Input Voltage			10.8V		
Torque Range	Hard Joint	Nm	0.5-2.0	0.8-3.0	1.5-4.5
		in-lbs	4.4-18	7.1-27	13-40
	Soft Joint	Nm	0.5-1.6	0.8-2.4	1.5-3.6
		in-lbs	4.4-14	7.1-21	13-32
Speed (rpm) HI/LO			2700/1900	1400/1000	800/550
Start Type			Trigger		
Weight (w/o battery)			0.7kg (1.5lbs)		
Size (L x H w/o battery)			189 x 157 mm (7.4 x 6.2 in)		
Applicable Battery			ESB-10VL2500		
Applicable Charging Station			ESB-CHG50N		
Applicable Bit Type			1/4" Hex		

*ESD-safe housing available on all models— add suffix '-ESD'



Compatible with
DR80-TH8-9
Tool Holster



LED indicators

Bottom	OK Clutch
	NG Clutch
Top	Low Speed Mode
	Low Battery

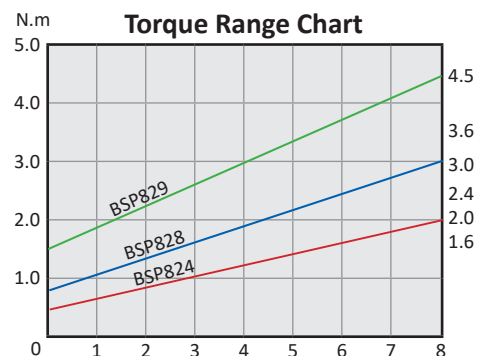

LITHIUM ION BATTERIES & BATTERY CHARGERS

ESB-7VL2500 & ESB-10VL2500 Battery

Features:

- High-performance Li-ion technology
- Built-in protection prevents battery overcharge and over discharge, extending lifespan

Specifications		
Battery Model	ESB-7VL2500	ESB-10VL2500
Use with Tool Model	ESB823(F)	ESB8 Series, BSP8 Series
Voltage	7.2V	10.8V
Rating (mAh)	2500	
Dimensions (L x W x H)	51 x 44 x 70 mm 2 x 1.7 x 2.7 in	51 x 46 x 90 mm 2 x 1.8 x 3.5 in
Weight	119.3g / 0.3 lbs	200g / 0.4 lbs
Certification	CE, ETL	



ESB-CHG25 & ESB-CHG50N Charging Station

Features:

- Visual indicators show recharging status
- Audibly notifies user when battery is fully charged
- Full recharge ~40 minutes

Specifications		
Charger Model	ESB-CHG25	ESB-CHG50N
Charges Battery Model	ESB-7VL2500	ESB-10VL2500
Input	100-240V	90-240V
Output	8.4V, 3.0A	12.6V, 3.75A
Dimensions (L x W x H)	145 x 115 x 101 mm 5.7 x 4.5 x 3.9 in	145 x 115 x 93 mm 5.7 x 4.5 x 3.6 in
Weight	430g / 0.9 lbs	470g / 1.0 lbs
Certification	CE, ETL	

