



Profit from the Eagle Advantage®

Specification Sheet

Short Form Specifications

Eagle worktables, Budget series model _____. Top to be constructed of heavy gauge type 430 stainless steel with 1½" roll on front and rear, and sides turned down 90°. Open front with 1 ¼" O.D. galvanized tubular crossbracing on sides and rear. Top reinforced with hat channels and sound deadened. Constructed with uni-lok® patented gusset system with the gussets recessed into the hat channels to reduce lateral movement. Legs to be 1 ½" O.D. galvanized tubing, with galvanized gussets and 1" hi-impact plastic bullet feet.



worktable with flat top and tubular base
—shown with optional drawer

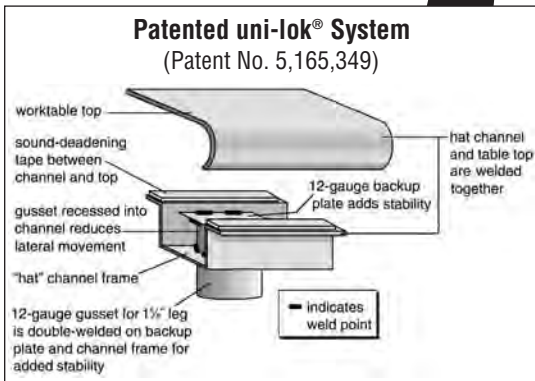

Item No.: _____
 Project No.: _____
 S.I.S. No.: _____

Worktables with Flat Top and Galvanized Tubular Base —Budget Series

MODELS:

- | | | | |
|-----------------------------------|------------------------------------|------------------------------------|------------------------------------|
| <input type="checkbox"/> T2424GTB | <input type="checkbox"/> T24108GTB | <input type="checkbox"/> T3072GTB | <input type="checkbox"/> T3660GTB |
| <input type="checkbox"/> T2430GTB | <input type="checkbox"/> T24120GTB | <input type="checkbox"/> T3084GTB | <input type="checkbox"/> T3672GTB |
| <input type="checkbox"/> T2436GTB | <input type="checkbox"/> T24132GTB | <input type="checkbox"/> T3096GTB | <input type="checkbox"/> T3684GTB |
| <input type="checkbox"/> T2448GTB | <input type="checkbox"/> T24144GTB | <input type="checkbox"/> T30108GTB | <input type="checkbox"/> T3696GTB |
| <input type="checkbox"/> T2460GTB | <input type="checkbox"/> T3030GTB | <input type="checkbox"/> T30120GTB | <input type="checkbox"/> T36108GTB |
| <input type="checkbox"/> T2472GTB | <input type="checkbox"/> T3036GTB | <input type="checkbox"/> T30132GTB | <input type="checkbox"/> T36120GTB |
| <input type="checkbox"/> T2484GTB | <input type="checkbox"/> T3048GTB | <input type="checkbox"/> T30144GTB | <input type="checkbox"/> T36132GTB |
| <input type="checkbox"/> T2496GTB | <input type="checkbox"/> T3060GTB | <input type="checkbox"/> T3648GTB | <input type="checkbox"/> T36144GTB |

Tabletop

- Patented uni-lok® gusset system (patent #5,165,349): gussets are recessed into hat channel, reducing lateral movement.
- Top reinforced with welded-on hat channel.
- Sound-deadened between top and channels.
- 1½" (38mm)-diameter 180° rolled edges on front and rear. Ends are turned down 90°, providing for flush installations when required.
- Heavy gauge type 430 polished stainless steel.

Crossbracing—1¼" (38mm)-diameter

- Heavy gauge, galvanized.
- Aluminum castings join crossbraces, legs and rear brace.

Legs—1½" (41mm)-diameter

- Tables 96" (2438mm) and longer come with six legs or more.
- Heavy gauge galvanized steel.
- 1" (25mm) adjustable hi-impact plastic feet.

Options / Accessories

- | | |
|--|--|
| <input type="checkbox"/> Drawer | <input type="checkbox"/> Duplex receptacles |
| <input type="checkbox"/> Lock | <input type="checkbox"/> Pot rack |
| <input type="checkbox"/> Casters | <input type="checkbox"/> Sink |
| <input type="checkbox"/> Stainless steel bullet feet | <input type="checkbox"/> Stabilizer Bar (for 30"- and 36"-wide tables) |
| <input type="checkbox"/> Overshelves | |

EAGLE GROUP
 100 Industrial Boulevard, Clayton, DE 19938-8903 USA
 Phone: 302-653-3000 • Fax: 302-653-2065
 www.eaglegrp.com

Foodservice Division: Phone 800-441-8440
MHC/Retail Display Divisions: Phone 800-637-5100

For custom configuration or fabrication needs, contact our **SpecFAB® Division**.
 Phone: 302-653-3000 • Fax: 302-653-3091 • e-mail: specfab@eaglegrp.com

Certifications / Approvals



EG10.42A Rev. 07/08

Spec sheets available for viewing, printing or downloading from our online literature library at www.eaglegrp.com

Eagle Foodservice Equipment, Eagle MHC, SpecFAB®, and Retail Display are divisions of Eagle Group. ©2008 by the Eagle Group



Item No.: _____
 Project No.: _____
 S.I.S. No.: _____

Worktables with Flat Top and Galvanized Tubular Base —Budget Series

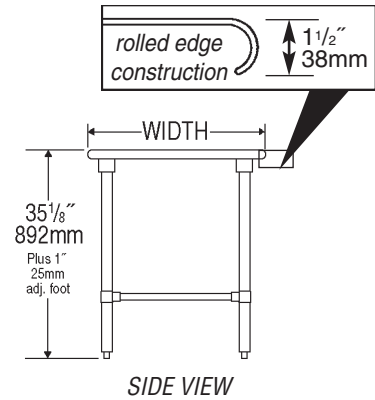
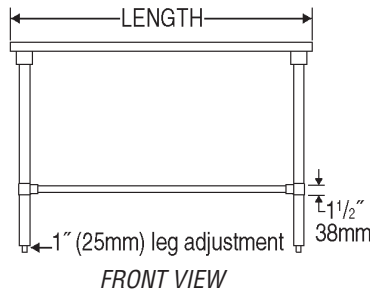
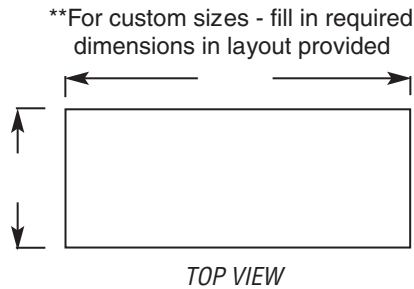

model #	# of legs	width		length		weight	
		in.	mm	in.	mm	lbs.	kg
T2424GTB	4	24"	610	24"	610	40	18.1
T2430GTB	4	24"	610	30"	762	45	20.4
T2436GTB	4	24"	610	36"	914	50	22.7
T2448GTB	4	24"	610	48"	1219	60	27.2
T2460GTB	4	24"	610	60"	1524	70	31.8
T2472GTB	4	24"	610	72"	1829	80	36.3
T2484GTB	4	24"	610	84"	2134	90	40.8
T2496GTB	6	24"	610	96"	2438	100	45.4
T24108GTB	6	24"	610	108"	2743	110	49.9
T24120GTB	6	24"	610	120"	3048	120	54.4
T24132GTB	8	24"	610	132"	3353	130	59.0
T24144GTB	8	24"	610	144"	3658	140	63.5
T3030GTB	4	30"	762	30"	762	47	21.3
T3036GTB	4	30"	762	36"	914	53	24.0
T3048GTB	4	30"	762	48"	1219	65	29.5
T3060GTB	4	30"	762	60"	1524	77	34.9
T3072GTB	4	30"	762	72"	1829	89	40.4
T3084GTB	4	30"	762	84"	2134	101	45.8
T3096GTB	6	30"	762	96"	2438	113	51.3
T30108GTB	6	30"	762	108"	2743	125	56.7
T30120GTB	6	30"	762	120"	3048	137	62.1
T30132GTB	8	30"	762	132"	3353	149	67.6
T30144GTB	8	30"	762	144"	3658	161	73.0
T3648GTB	4	36"	914	48"	1219	73	33.1
T3660GTB	4	36"	914	60"	1524	87	39.5
T3672GTB	4	36"	914	72"	1829	101	45.8
T3684GTB	4	36"	914	84"	2134	115	52.2
T3696GTB	6	36"	914	96"	2438	129	58.5
T36108GTB	6	36"	914	108"	2743	143	64.9
T36120GTB	6	36"	914	120"	3048	157	71.2
T36132GTB	8	36"	914	132"	3353	171	77.6
T36144GTB	8	36"	914	144"	3658	185	83.9

EAGLE GROUP
 100 Industrial Boulevard, Clayton, DE 19938-8903 USA
 Phone: 302-653-3000 • Fax: 302-653-2065
 www.eaglegrp.com

Foodservice Division: Phone 800-441-8440
 MHC/Retail Display Divisions: Phone 800-637-5100

Printed in U.S.A.
 ©2008 by Eagle Group

Rev. 07/08

Spec sheets available for viewing, printing or downloading from our online literature library at www.eaglegrp.com

Although every attempt has been made to ensure the accuracy of the information provided, we cannot be held responsible for typographical or printing errors. Information and specifications are subject to change without notice. Please confirm at time of order .